

DURA

SPRAYER II



OPERATING MANUAL

DuraSprayerII™ OPERATING MANUAL

Thank you and Congratulations on your choice of the DuraSprayerII™, a revolutionary disinfectant delivery system that uniquely combines the technology of foggers, misters, refillable sprayers, and prepackaged aerosols.

This refillable unit eliminates the need for costly prepackaged aerosols by mechanically generating the most optimum-sized, uniform disinfectant particles. Its unique design allows you to treat more area per ounce than with pre-packaged aerosol products.

Its handy size and its portability make it an invaluable tool for use in your home, office, gym both residential and light commercial accounts. In addition, it gives you the flexibility of using a variety of disinfectants that are EPA approved for use in this type of equipment.

Manufactured for:



DURALINE
BIOSYSTEMS INC

Clean
to Sterile
Solutions™

39 Western Highway
West Nyack, NY 10994
877-561-0500

Table of Contents

OPERATING INSTRUCTIONS	Page 2-4
DISINFECTANTS	Page 2
RECHARGING	Page 4
EQUIPMENT SPECIFICATIONS	Page 5
PARTS AND SERVICE	Page 6-7
DIAGNOSIS AND FIELD SERVICE	Page 6
WARRANTY	Page 8

OPERATING INSTRUCTIONS

Handle with care.

Always wear personal protective equipment (PPE)

When filling these units always wear protective eyewear and protective gloves. When operating these units, always wear protective clothing, eyewear, chemical resistant rubber gloves, and a respirator. Refer to the disinfectant label for specific instructions and other precautions.

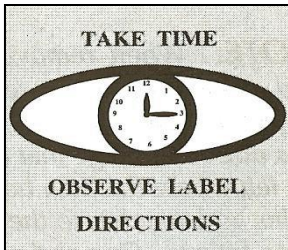

Preparations and Guidelines when applying Aerosol Disinfectants.

Refer to disinfectant label for directions on proper preparation for area to be treated before operating this equipment. General preparation includes:

Everyone in the treatment area must wear an approved respirator during treatment and when re-entering a treated area when the aerosol may still be present. Turn off all pilot lights or sources of open flame. Ventilation systems and air moving systems should be turned off. Appliances that routinely create high heat should be turned off. Computers and other electrical equipment should be turned off, covered, or removed from the treatment area.

All personnel without proper PPE must leave the treatment area. Cover or remove ornamental plants. Cover and seal all aquariums. Aquarium filters must be shut off and not turned back on until the aerosol is no longer present. Pets, including exotic pets (birds, amphibians, reptiles, arachnids) must be removed. Re-entry for exotic pets is not recommended for a period of 24 hours.

All exposed food must be removed or placed in containers that will prevent contact with the disinfectant. Food preparation utensils and surfaces must be covered or cleaned thoroughly before reuse. Close and lock all entry ways.

Professionals may want to consider posting warning signs on doors opening into the treatment site. Open all doors, cabinets, storage areas, and drawers in the treatment area.

Observe Label Directions of Disinfectant Solution:

Do not operate the DuraSprayerII™ with disinfectants that are not labeled for aerosol, fog, or mist applications. Read the disinfectant label to determine if the disinfectant is EPA-approved for use in this type of equipment. Contact your chosen distributor for information on disinfectants currently labeled for use in equipment such as DuraSprayerII™

Prepare Disinfectant Solution:

Must follow all directions on the packaging of the disinfectant. Some solution comes ready to use. Some needs to be pre-mixed.

Fill Tank with Disinfectant:

Remove white container by unscrewing from the main sprayer unit. Once container is filled, place the tubing into container and carefully screw the container back on to the sprayer unit until it is hand tight. There is no filter, so be sure to remove any debris that you notice that may clog or damage the DuraSprayerII™ equipment.

Turn the unit on to begin use:

Push the On/Off button on the back of the unit. The solution will start to flow; keep the sprayer in motion, making sure to cover all areas.

Flush System After Every Use to Remove Chemicals

This procedure is highly recommended and is the most important maintenance you can do for your sprayer. Simply place the tubing into a water and run for one minute to clean out the disinfectant from the sprayer.

Draining the Container.

Empty the DuraSprayerII™ container when changing disinfectants or storing for an extended period of time. Also wash with water and let it dry before storing.

Transporting the Unit.

If transporting the DuraSprayerII™ with disinfectant in the container, it must be kept in an upright position. Container must be emptied if this is not possible. If the solution leaks into the motor, it could damage it (This is not covered under the warranty).

Recharging the DuraSprayerII™

When fully charged, the four lights on the back light up. If only one or no light is showing, the unit needs to be recharged for 4 hours. Simply lift up on the back of the battery and pull it out. Plug the charger into the battery and leave until fully charged.

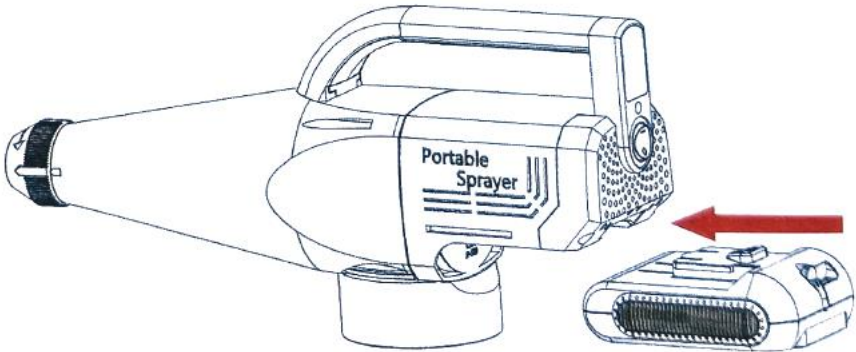

Battery LED lights

DuraSprayerII™ SPECIFICATIONS

Length	13.8"
Width	3.2"
Height	5.9"
Weight (empty)	3 lbs.
Weight (full)	6 lbs.
Shipping Weight	4 lbs.
Tank Capacity	1/2 gallon (1.8 liters)
Voltage	20V
Spraying Distance	9-16 feet
Motor	6 amps, 129 watts
Noise Level	~75 DB
Operating Time	25-30 minutes

PARTS

Parts for the DuraSprayerII™ can be ordered through your chosen distributor. Or, for your convenience, we maintain a large inventory of replacement parts which can easily be ordered and shipped directly from our factory to you.

Call Today: 1-877-561-0500 we accept:



SERVICE

If the DuraSprayerII™ requires factory service be sure to drain the tank, back flush the wand and hose, and pack the unit in its original carton and packing material for shipping. If the original carton is not available, pack the unit a durable box and protect the unit as best you can. If using foam packing materials be sure to place the unit in a plastic bag before adding materials to carton.

Ship the unit with a description of the problem, a contact name and phone number, and a return shipping address to:

Duraline Systems, Inc.
39 Western Highway
West Nyack, NY 10994

NOTE: Post Warranty service will be billed for parts, labor, packaging (if needed), and freight.

DIAGNOSIS AND FIELD SERVICE

If none of these solutions corrects your problem, there may be something more serious wrong with the unit. For additional technical assistance please contact Duraline Systems, Inc. Help Desk at 877-561-0500.

DuraSprayerII™ Parts List

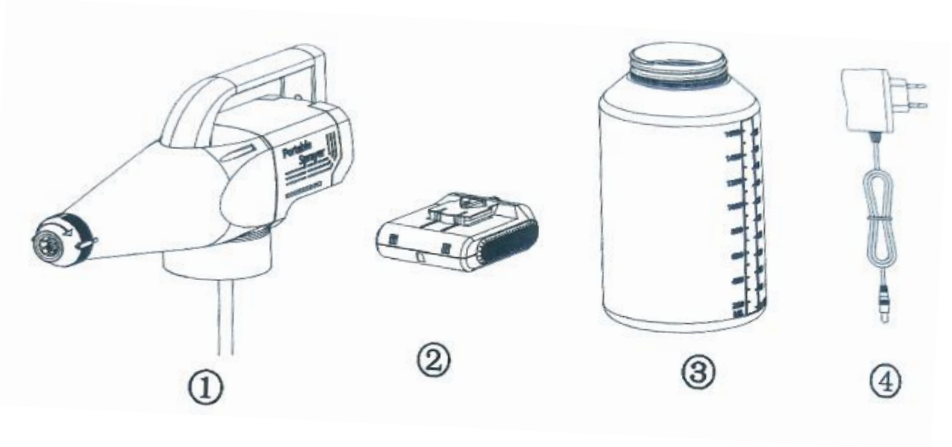

Description	Reorder No.
Sprayer Unit	C-DSDII-SU
Battery Pack	C-DSDII-BP
1.8 Liter Bottle	C-DSDII-B
Charger	C-DSDII-C

PRODUCT LIMITED WARRANTY

Duraline Systems, Inc. products are warranted to be defect free in materials and workmanship under normal use, for a period of 90 days from the date of purchase.

Duraline Systems, Inc. shall not be liable for freight damage incurred during shipping. Package returns carefully. If the original carton is not available, pack the unit in a durable box and protect the unit as best you can.

Duraline Systems, Inc.'s obligation under this warranty policy is limited to the repair or replacement of the unit. All returns will be tested per Duraline Systems, Inc. factory criteria. Units found not defective, under the terms of this limited warranty, are subject to the charges paid by the returnee.

Warranty replacement will be shipped on a freight allowed basis Duraline Systems, Inc. reserves the right to choose the method of transportation.

This limited warranty is in lieu of all other warranties, expressed or implied, and no other person is authorized to give any other warranty or assume obligation or liability on Duraline Systems, Inc.'s behalf. Duraline Systems, Inc. shall not be liable for any labor, damage or other expense, nor Duraline Systems, Inc. be liable for any indirect, incidental or consequential damages of any kind incurred by the reason of the use or sale of any defective product or part.

Return Policy

All units must be flushed of any chemicals before shipping. Carriers, including U.S.P.S., airlines, UPS, ground freight, etc. require specific identification of any hazardous materials to be shipped. Failure to do so may result in a substantial fine and/or prison term. Check with your shipping company for specific instructions.

All Units must be flushed of any chemical (ref. OSHA Section 1910.1200 (d)(e)(f)(g)(h)) and NO hazardous chemicals will be accepted for service or warranty consideration Duraline Systems, Inc. reserves the right to request a Material Safety Data Sheet from the returnee for any product it deems necessary. Duraline Systems, Inc. reserves the right to "disposition as scrap" any products returned which contain unknown fluids. Duraline Systems, Inc. reserves the right to charge the returnee for all costs incurred for chemical testing and proper disposal of components containing unknown fluids. Duraline Systems, Inc. requests this in order to protect the environment and personnel from the hazards of handling unknown fluids



Manufactured for:



39 Western Highway
West Nyack, NY 10994
877-561-0500

Copyright© 2020 Duraline Systems,