



Andersen EOGas Sterilizers combine the proven reliability of ethylene oxide with a unique delivery system that uses less than 11cc of gas per cycle - almost 90% less gas than our closest competition. EOGas is the most delicate sterilization system on the market and will not damage delicate items such as electronics, fiber-optics, endoscopes, cameras, or laptop computers. Ideal for long lumens, heat sensitive materials, and plastics. Bag and cartridge size can be customized to your product. Fully validatable - for medical device manufacturing.

## EOGas - The State of the Art in Ethylene Oxide Sterilization



Unique sterilization system uses unit dose cartridges and plastic sterilization bags, *no external EO tanks.*

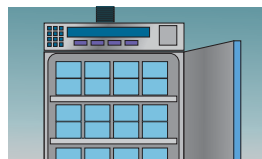

*Batch processing* for small production lots in the manufacture of medical devices.



*Multi-load capability* (not available for validated cycles) allows you to add loads as needed.



*Microprocessor control* keeps track of when each bag is loaded and when it is ready to be removed. No more waiting for a cycle to finish before adding another load.



An Andersen Products Authorized Distributor

Order online: [www.duralinesystems.com](http://www.duralinesystems.com)

Email: [sales@duralinesystems.com](mailto:sales@duralinesystems.com)

Call: 877-561-0500



AN306

AN333

AN310

# EOGas<sup>®</sup> series 3 plus STERILIZER TECHNICAL SPECIFICATIONS

## AN306

Inner - 24.5"W (62.23cm) x 22.25"D (56.52cm) x 16.5"H (41.91cm)  
 Overall Outer - 36.25"W (92.08cm) x 31.375"D (79.69cm) x 30"H (76.2cm)  
 B: 36" with label printer mount C: Side view 31.375" W with UPS

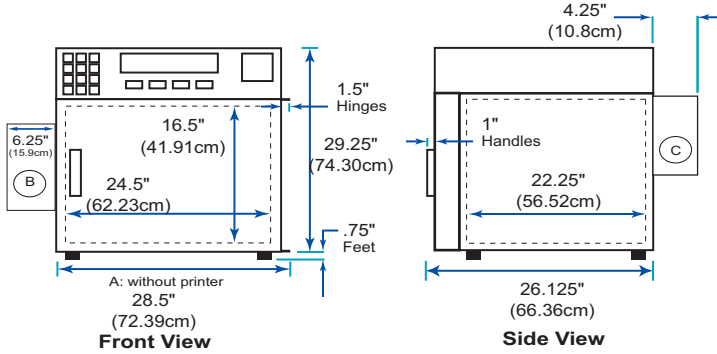

## AN333

Inner - 31"W (78.74cm) x 28"D (71.12cm) x 65.5"H (166.37cm)  
 Overall Outer - 43"W (109.22cm) x 36.75"D (93.35cm) x 77.75"H (197.49cm)  
 B: 43" with label printer mount C: Side view 36.75" W with UPS

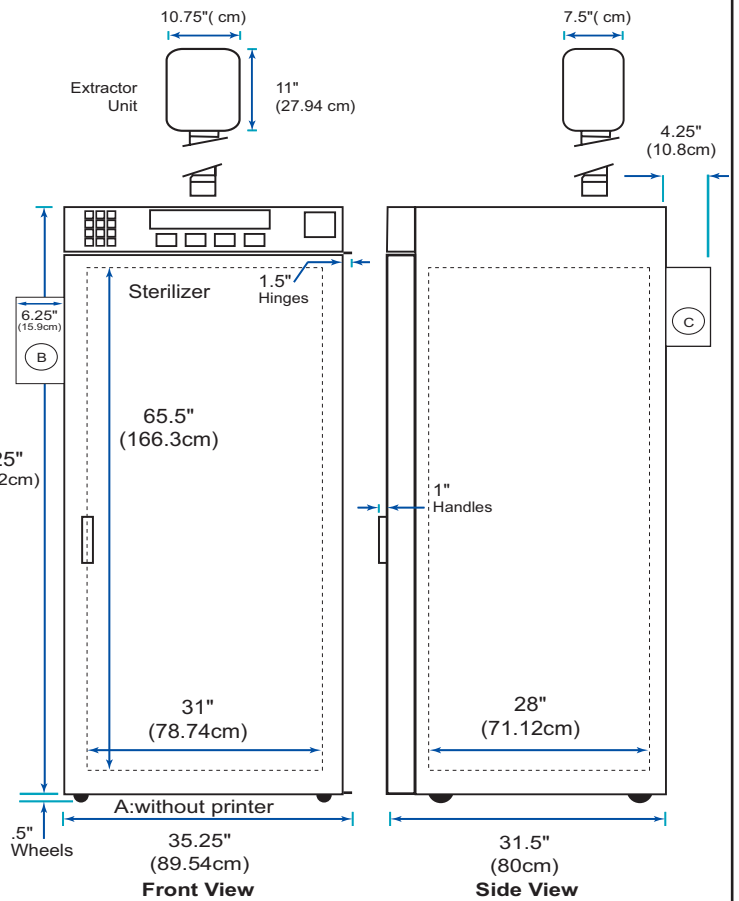

## AN310

Inner - 24.5"W (62.23cm) x 22.25"D (56.52cm) x 26.5"H (67.31cm)  
 Overall Outer - 36.25"W (92.08cm) x 31.375"D (79.69cm) x 39.75"H (100.96cm)  
 B: 36.25" with label printer mount C: Side view 31.375" W with UPS

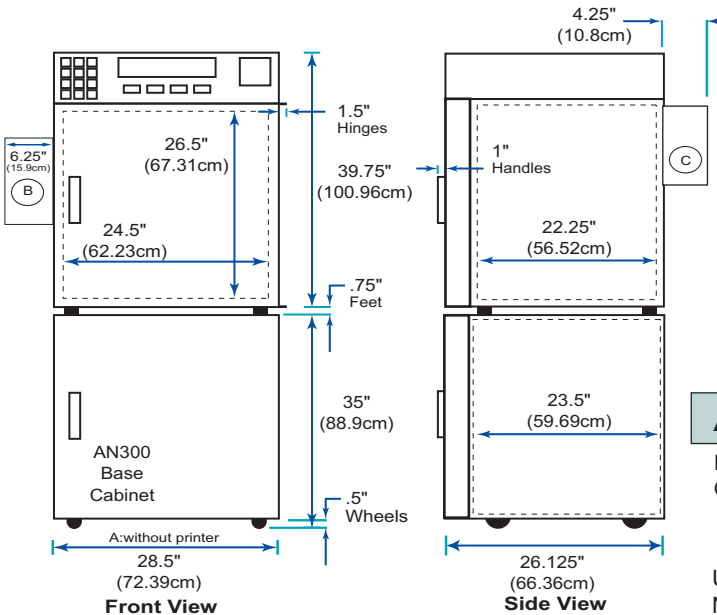

## AN300 Base Cabinet

Inner - 24.5"W (62.23cm) x 23.5"D (59.69cm) x 28"H (71.12cm)  
 Outer - 28.5"W (72.39cm) x 26.125"D (66.35cm) x 35"H (88.9cm)

UL Std. No. 3101-1, CSA C22.2 No. 1010.1-921, IEC Std. 1010-1  
 National Certification Body-CSA LR 25596-17

Model No.	Description	Capacity	Operational Weight		Exhaust Requirements	Power Requirements
			Cabinet	Extractor		
AN306	Table-top sterilizer cabinet and extractor unit	6 cu ft	245 lbs (112 kg)	10 lbs (4.5 kg)	Dedicated 3" (7.6 cm) discharge vent	110/120 V, 50/60 Hz, 10.75 Amps (220/240 V, 50/60 Hz, 5.4 Amps)
AN310	Free-standing sterilizer cabinet and extractor unit	10 cu ft	285 lbs (130 kg)	10 lbs (4.5 kg)	Dedicated 3" (7.6 cm) discharge vent	110/120 V, 50/60 Hz, 10.75 Amps (220/240 V, 50/60 Hz, 5.4 Amps)
AN333	High-capacity free-standing sterilizer and extractor unit	33 cu ft	630 lbs (286 kg)	10 lbs (4.5 kg)	Dedicated 3" (7.6 cm) discharge vent	220/240 V, 50/60 Hz, 5.4 Amps

Anpro<sup>®</sup> and EOGas<sup>®</sup> are trademarks of Andersen Products, Inc.



An Andersen Products Authorized Distributor

39 Western Hwy, West Nyack, NY 10994  
 sales@duralinesystems.com  
 Call: (877) 561-0500  
 www.duralinesystems.com